

Centre Number	Candidate Number	Name
---------------	------------------	------

UNIVERSITY OF CAMBRIDGE INTERNATIONAL EXAMINATIONS
General Certificate of Education Ordinary Level

COMBINED SCIENCE **5129/02**

Paper 2 May/June 2005

2 hours 15 minutes

Candidates answer on the Question Paper.
No Additional Materials are required.

READ THESE INSTRUCTIONS FIRST

Write your Centre number, candidate number and name on all the work you hand in.
Write in dark blue or black pen in the spaces provided on the Question Paper.
You may use a soft pencil for any diagrams, graphs or rough working.
Do not use staples, paper clips, highlighters, glue or correction fluid.

Answer **all** questions.
The number of marks is given in brackets [] at the end of each question or part question.
A copy of the Periodic Table is printed on page 24.

If you have been given a label, look at the details. If any details are incorrect or missing, please fill in your correct details in the space given at the top of this page.

Stick your personal label here, if provided.

For Examiner's Use

- 1 Fig. 1.1 shows the electronic structure of an atom of chlorine.

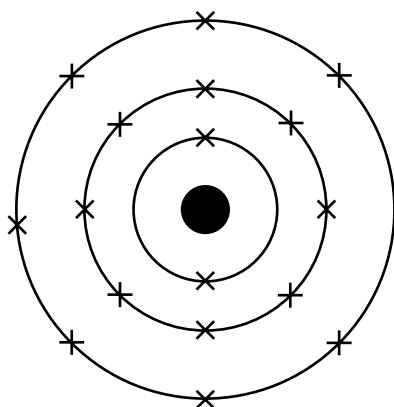

Fig. 1.1

- (a) (i) State the Group of the Periodic Table in which chlorine is placed.

.....

- (ii) Use the information in Fig. 1.1 to give a reason for your answer to (a)(i).

.....

..... [2]

- (b) Chlorine exists as a diatomic molecule. Draw a diagram of a chlorine molecule showing the outer electrons only.

[2]

- (c) Chlorine reacts with an aqueous solution of potassium iodide producing potassium chloride and iodine.

- (i) State the type of reaction that takes place.

.....

- (ii) Construct an equation for the reaction.

.....

[2]

- 2 (a) (i) Name a nitrogen-containing ion that is essential to plants.

.....

- (ii) State the use of this ion in a growing plant.

.....

.....

[2]

- (b) A farmer wants to add the ion named in (a)(i) to the soil.
Name a compound that the farmer could spread on the fields to add this ion.

.....[1]

- (c) Suggest how a river flooding a field can remove the ion from the soil.

.....

.....[1]

- 3 Fig. 3.1 shows how the displacement of particles in a wave varies with distance along the wave.

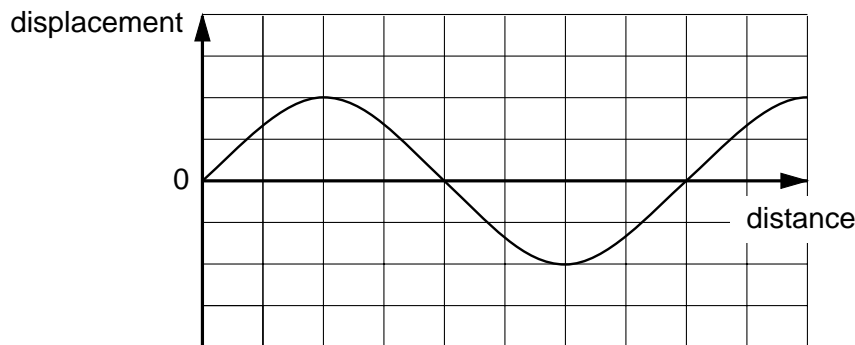

Fig. 3.1

- (a) On Fig. 3.1 draw a line to show a wave with the same amplitude and with half the wavelength. [2]

- (b) Name the region of the electromagnetic spectrum with waves of

(i) the longest wavelength,

(ii) the shortest wavelength.[2]

- 4 Fig. 4.1 shows three lamps and switches connected to a cell. All the switches are open.

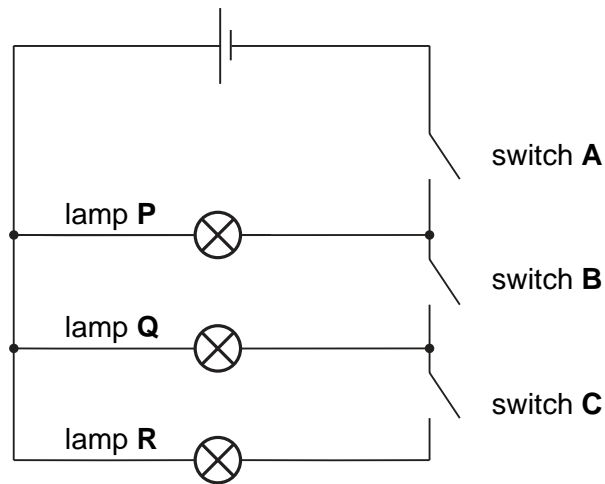

Fig. 4.1

- (a) State which lamp or lamps, if any, light when switch **A only** is closed.
[1]
- (b) State which switches must be closed to make lamp **Q** light but **not** lamp **R**.
[1]
- (c) When all the lamps are lit, the current through each lamp is 0.25 A.
 Calculate the current from the cell.
A [1]
- (d) An ammeter is used to measure the current from the cell.
 On Fig. 4.1, mark with the letter **X** a suitable position for the ammeter. [1]

5 Indigestion is caused when too much acid is produced in the stomach. Indigestion may be cured by chewing tablets containing magnesium carbonate.

- (a) An indigestion tablet containing magnesium carbonate is crushed and shaken with water and Universal Indicator solution is added.

State the final colour of the solution.[1]

- (b) The acid present in the stomach is hydrochloric acid.
The equation for the reaction between magnesium carbonate and hydrochloric acid is



- (i) Name the ion that is present in aqueous hydrochloric acid and all other aqueous acids.

.....[1]

- (ii) State the type of reaction that occurs between hydrochloric acid and magnesium carbonate.

.....[1]

- (iii) Describe a test that you could use to prove carbon dioxide is given off in the reaction.

test.....

.....

result.....

.....[2]

6 Fig. 6.1 shows the human alimentary canal.

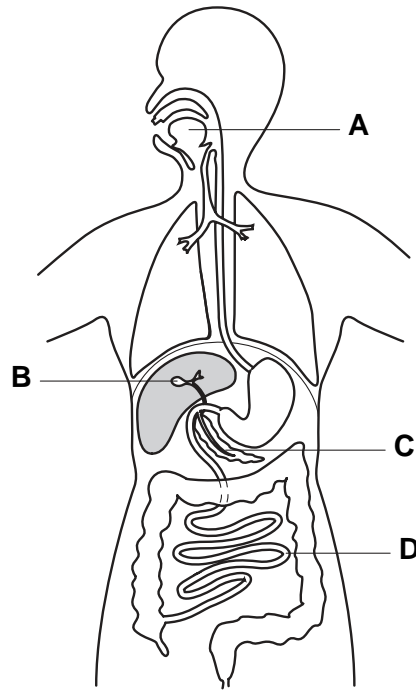

Fig. 6.1

(a) Name the parts labelled.

- A.....
- B.....
- C.....
- D.....[4]

(b) A person eats some bread.

State two effects of saliva on the bread.

1.
2.[2]

(c) Fig. 6.2 shows some of the bread as it moves down part of the alimentary canal.

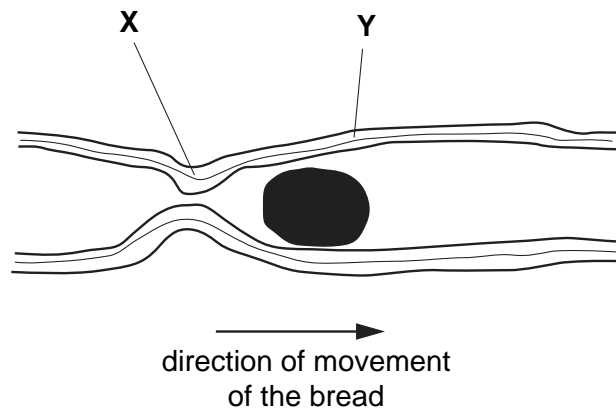

Fig. 6.2

(i) Name the process that causes the movement.

.....[1]

(ii) State what the muscles of the intestine are doing at point **X** and at point **Y**.

X

Y[2]

7 Fig. 7.1 shows an electromagnet.

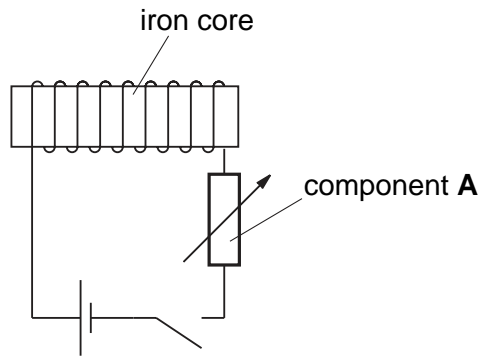

Fig. 7.1

(a) Name component **A**.[1]

(b) State **one** way in which the strength of the electromagnet can be increased.
.....[1]

(c) The core is made of iron rather than steel.
State **one** difference between the magnetic properties of iron and steel.
.....[1]

8 A suspended balloon is rubbed with a duster. This produces a negative charge on the balloon.
A charged acetate strip is brought near to the balloon. The balloon moves towards the acetate strip as shown in Fig. 8.1.

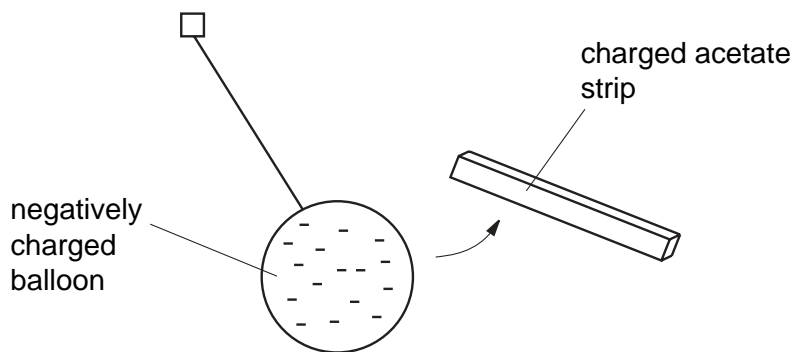

Fig. 8.1

Explain why the balloon moves towards the acetate strip.
.....
.....
.....[2]

9 Petrol, hydrogen and ethanol are used as fuels for cars.

(a) (i) Name **one** of these three fuels that produces carbon monoxide as it burns.

.....

(ii) Name **one** of these three fuels that produces sulphur dioxide as it burns.

.....

[2]

(b) When sulphur dioxide escapes into the environment it dissolves in water to produce acid rain. State two effects of acid rain on the environment.

1.

2.[2]

(c) State the gas, present in the air, that is needed for any fuel to burn.

.....[1]

(d) Suggest how the process of respiration is similar to the combustion of fuels.

.....

.....[2]

10 Ammonia is manufactured by reacting nitrogen with hydrogen in the presence of a catalyst.

(a) Balance the equation for the reaction.



(b) State the temperature and the pressure used in the manufacture of ammonia.

temperature°C

pressureatm [2]

(c) (i) Name the catalyst used in the manufacture of ammonia.

.....

(ii) Give a reason why a catalyst is used in the process.

.....

.....

[2]

11 Fig. 11.1 shows the male reproductive system.

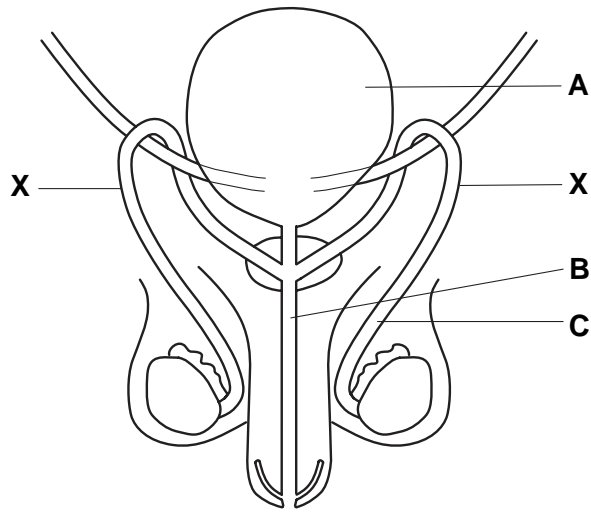

Fig. 11.1

(a) Name and give the function of each of the structures labelled **A**, **B** and **C**.

A name.....

function

.....
.....

B name.....

function

.....
.....

C name.....

function

.....
.....

[6]

(b) Cutting both of the tubes shown at the points marked **X** is a form of contraception.

(i) Explain why this method is effective.

.....
.....[1]

(ii) Suggest **one** advantage and **one** disadvantage of this method of contraception.

advantage

.....

disadvantage

.....[2]

- 12 Two plane mirrors are used to reflect a ray of light. The ray of light follows the path shown in Fig. 12.1.

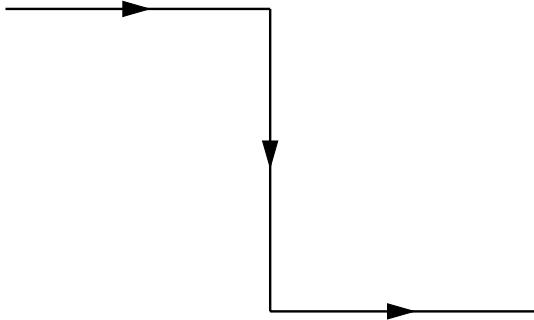

Fig. 12.1

On Fig. 12.1, draw two plane mirrors in the correct positions to reflect the ray along this path. [2]

13 Nuclei of a radioactive isotope of iodine, $^{131}_{53}\text{I}$, emit beta-particles.

(a) Calculate the number of neutrons in a nucleus of $^{131}_{53}\text{I}$.

.....[1]

(b) When a nucleus of $^{131}_{53}\text{I}$ emits a beta-particle, state the change in

(i) the number of neutrons,

(ii) the number of protons.

[2]

(c) The half-life of $^{131}_{53}\text{I}$ is eight days.

Sixteen days ago, a sample of $^{131}_{53}\text{I}$ emitted 16 000 beta-particles per second.

(i) Calculate the number of half-lives in sixteen days.

(ii) Use your answer to (c)(i) to calculate the number of beta-particles now emitted per second by the sample.

[3]

14 (a) Define *relative atomic mass*.

.....
.....[2]

(b) An element, X, is extracted from the oxide of the element, X_2O_3 , by reduction with carbon.

The equation for the reaction is

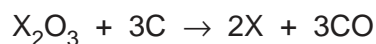

The relative molecular mass of X_2O_3 is 160.

(i) Calculate the relative atomic mass of X.

[A_r: O,16]

.....
.....[1]

(ii) Calculate the mass of carbon that reacts with 8.0 g of the oxide, X_2O_3 .

[A_r: C,12]

.....
.....
.....[2]

15 (a) Many human mothers feed their babies on breast milk.

(i) State what is in breast milk that helps babies' muscles to develop.

.....

(ii) Name the mineral in breast milk that helps babies' haemoglobin to develop.

.....

(iii) State what is in breast milk that helps a baby to overcome a disease such as influenza.

.....

[3]

(b) (i) Suggest two advantages, other than those in (a), of breast milk rather than powdered milk mixed with water.

1.

.....

.....

2.

.....

.....

(ii) Suggest a disadvantage of feeding babies on breast milk.

.....

.....

[3]

- 16 (a) State the formula used to calculate the moment of a force.

.....[1]

- (b) Fig. 16.1 shows a spanner being used to tighten a nut.

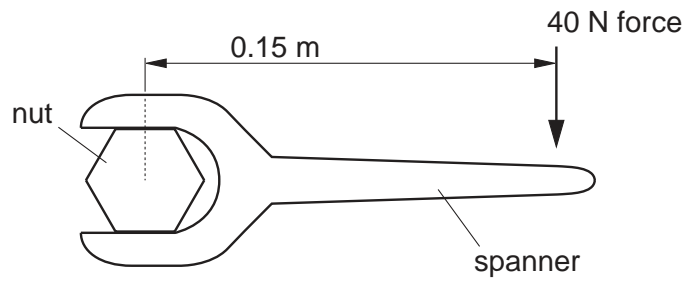

Fig. 16.1

Calculate the moment of the 40 N force about the centre of the nut.

[2]

17 A kettle, as shown in Fig. 17.1, has a power rating of 1500 W.

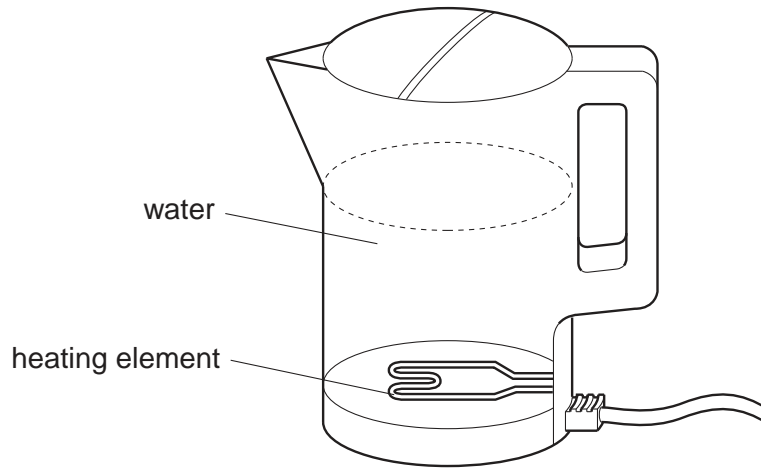

Fig. 17.1

(a) Explain what is meant by the term *power rating*.

.....
.....[1]

(b) The connecting wire of the kettle is fitted with a plug containing a fuse.
State whether the fuse is connected into the live, neutral or earth lead.

.....[1]

(c) The water at the bottom of the kettle is heated.
Explain, in detail, how the rest of the water in the kettle is heated by convection.

.....
.....
.....[3]

18 Study the reactions shown in Fig. 18.1.

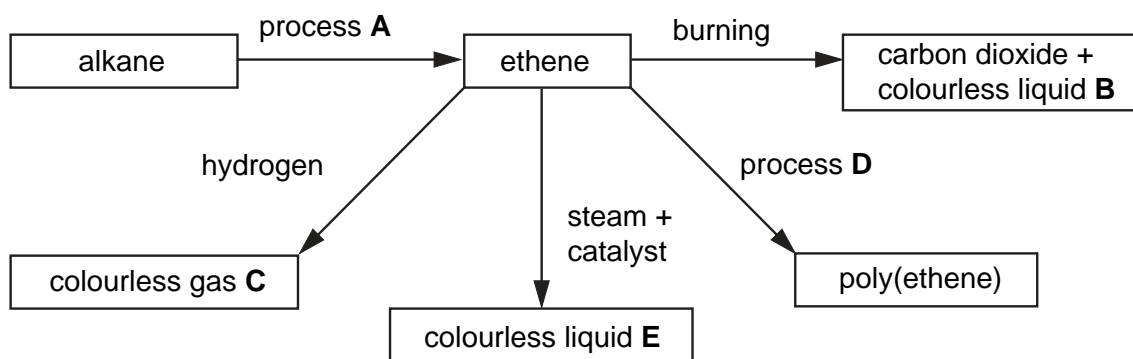

Fig. 18.1

(a) Identify the processes **A** and **D**.

process **A**

process **D**

[2]

(b) Identify the substances **B**, **C** and **E**.

substance **B**

substance **C**

substance **E**

[3]

(c) Draw a diagram to show the structure of ethene.

[1]

19 Fig. 19.1 shows part of the carbon cycle.

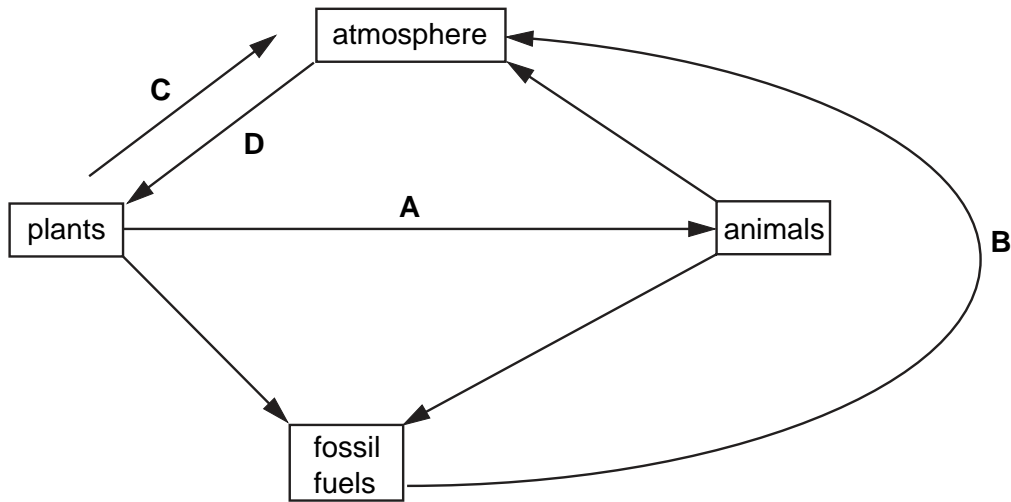

Fig. 19.1

(a) Name a compound containing carbon that is found in the Earth's atmosphere.

.....[1]

(b) Name the processes labelled **A**, **B**, **C** and **D**. Choose only words from the list below. You may use the words once, more than once or not at all.

combustion decomposition feeding photosynthesis respiration

A

B

C

D

[4]

20 A ball is thrown horizontally from a tall building and it follows the path shown in Fig. 20.1.

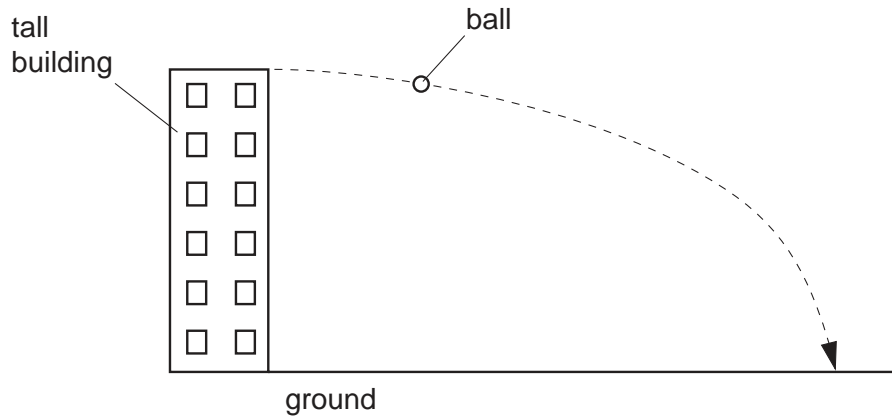

Fig. 20.1

- (a) How can you tell from the path of the ball that there is a force acting on it?
[1]
- (b) On Fig. 20.1 draw an arrow to show the direction of the force on the ball after it has left the building. [1]
- (c) State the form of energy
 - (i) lost by the ball as it falls to the ground,
 - (ii) gained by the ball as it falls to the ground.[2]

BLANK PAGE

Permission to reproduce items where third-party owned material protected by copyright is included has been sought and cleared where possible. Every reasonable effort has been made by the publisher (UCLES) to trace copyright holders, but if any items requiring clearance have unwittingly been included, the publisher will be pleased to make amends at the earliest possible opportunity.

University of Cambridge International Examinations is part of the University of Cambridge Local Examinations Syndicate (UCLES), which is itself a department of the University of Cambridge.

